

## Portable Compressors **MOBILAIR M27/M31**

With the world-renowned SIGMA PROFILE 

Free air delivery 1.90 to 3.15 m<sup>3</sup>/min



**M27 / M31**

# MOBILAIR M 27 / M 31

## Compact, powerful, versatile

Kaeser's new MOBILAIR portable compressors provide more than just impressive free air delivery: Various equipment options transform these efficient compressors into multi-talented compressed air powerhouses.

### Pile on the pressure

As with every KAESER rotary screw compressor, a premium quality airend featuring world-renowned SIGMA PROFILE rotors lies at the heart of all M 27 and M 31 models and delivers more compressed air with less energy consumption. The standard working pressure for these machines is 7 bar; 10, 12 and 14 bar versions are also available.

### Compact powerhouse

The MOBILAIR M 31 is more than just a reliable air compressor. With the optionally available 6.5 kVA generator, it becomes a construction site powerhouse providing a dependable supply of compressed and / or electricity.

### Compressed air quality

Aftercoolers and condensate separators are available for applications requiring cool, dry compressed air. The M 27 and M 31 compressors without air treatment systems feature Kaeser's patented Anti-Frost Control as standard. Together with an optional tool lubricator, the Anti-Frost Control prevents compressed air tools from freezing up, even with cold outside temperatures.

### Useful extras

A multitude of carefully considered options makes these portable compressors even more versatile: For example, a hose reel with twenty metres of lightweight hose, a toolbox for convenient storage and a closed floor pan. A version designed for use in refineries is available, which includes a spark arrestor and a motor shutoff valve. A check valve is provided for sandblasting applications.



### Design variants

A version with a sheet steel enclosure, conveniently located control panel and drain valves is available for stationary installation on trucks.

## Compact and versatile







# MOBILAIR M27/M31

## Efficient and tough



### Powerful energy-saving team

The KAESER rotary screw airend with energy-saving SIGMA PROFILE rotors is driven via gearing by a tough, water-cooled three-cylinder Kubota diesel engine. An electric fuel pump makes fuel line venting simple.



### Service-friendly

The wide-opening enclosure provides excellent component access, which makes service work a breeze thereby ensuring maximum compressed air availability.



### Impressive performance

The PE fuel tank fits perfectly into the available space and holds enough diesel fuel for extended operation without refuelling. A cleaning opening is located in the floor pan which ensures that the machine can be kept clean and running at optimum performance.



### Cool, dry compressed air

The compressed air aftercooler cools the compressed air to 7°C above ambient. Because the aftercooler is installed at an angle the condensate is able to easily drain away. This environmentally-friendly design prevents problems caused by freezing in winter and the condensate is evaporated using the hot exhaust gases from the engine.





# MOBILAIR M27/M31

## Multiple equipment options for maximum versatility



### Enclosure types

The stationary versions of the M 27 and M 31 feature a metal enclosure. Towable versions are available with either a soundproof, galvanized and powder-coated steel enclosure or a double-walled soundproof rotomolded polyethylene enclosure.



### Generator option

A brushless, maintenance-free, 6.5 kVA synchronous generator (IP54) is optionally available. It can be switched from continuous mode to energy-saving on-off mode depending on the amount of power required. This option transforms the M 31 into a versatile construction site powerhouse.



### Easy to operate

The low position height of the operating panel and other controls on the metal enclosure version makes these packages perfect for installation on flatbed trucks. Operation is made simple via user-friendly icons and a single start switch.



### On the safe side

On the M 31 equipped with a polyethylene canopy, the generator control panel is safely tucked into the plastic moulding that protects the corners of the unit. Additional safety features include IP 44-enclosed sockets, a lockable main breaker and an isolating switch with insulation monitoring.



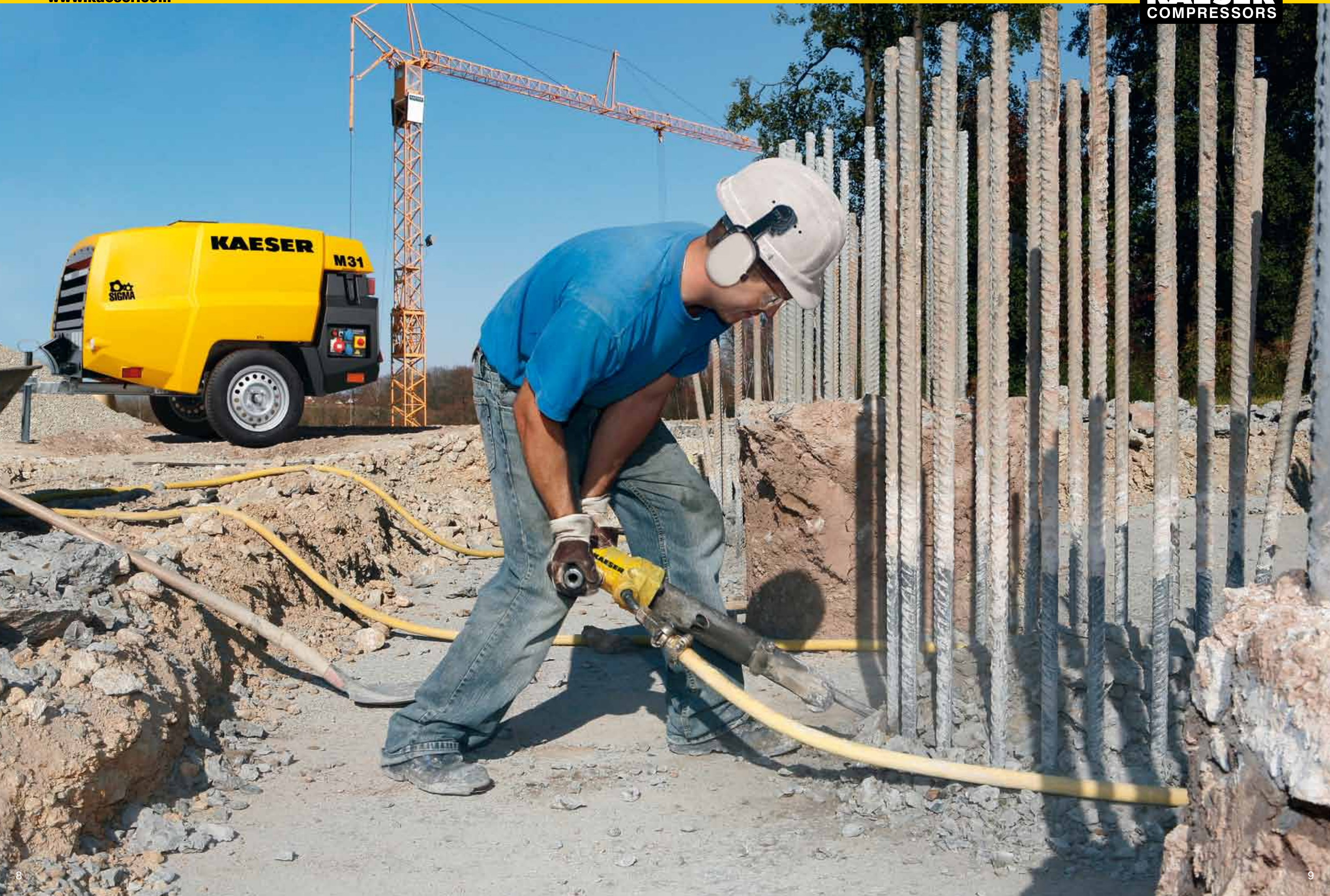



## Equipment

### Dedicated intake filter

Optimally sized separate air filter for the compressor and motor for enhanced reliability and service life; filters can be quickly cleaned or replaced on site.

### Oil temperature control as standard

Automatic thermostatic valve ensures fast warm-up: the compressor quickly reaches and stays at its optimal operating temperature; no excessive condensate accumulation in the compressor oil circuit; long-lasting separator cartridge; packages without air treatment or B variant additionally available with Anti-Frost Control.

### Ambient temperature

Standard rating of -10° C to +45° C; a low-temperature version with engine coolant pre-heater available for extremely cold starts.

### Simple operation

Ignition switch with glow plug pre-heat feature; operation via intuitive icons; fully automatic monitoring; automatic shutdown on fault; display of operating hours, operating pressure and airtend discharge temperature; main breaker inside the lockable enclosure.

### Tough Al-Ko chassis

All chassis galvanised; with or without overrun brake; with or without tow bar height adjustment.

## Alternative colours

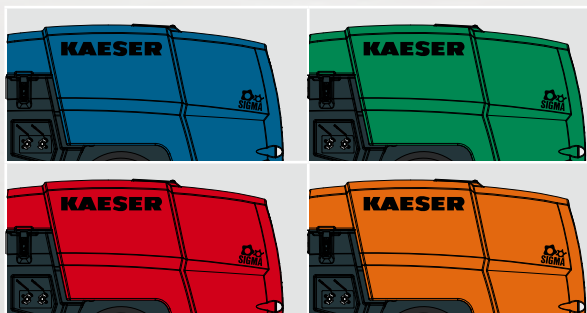

The polyethylene enclosure is available in the following colours:

- Blue – Equivalent to RAL 5017
- Green – Equivalent to RAL 6024
- Red – Equivalent to RAL 3020
- Orange – Equivalent to RAL 2009



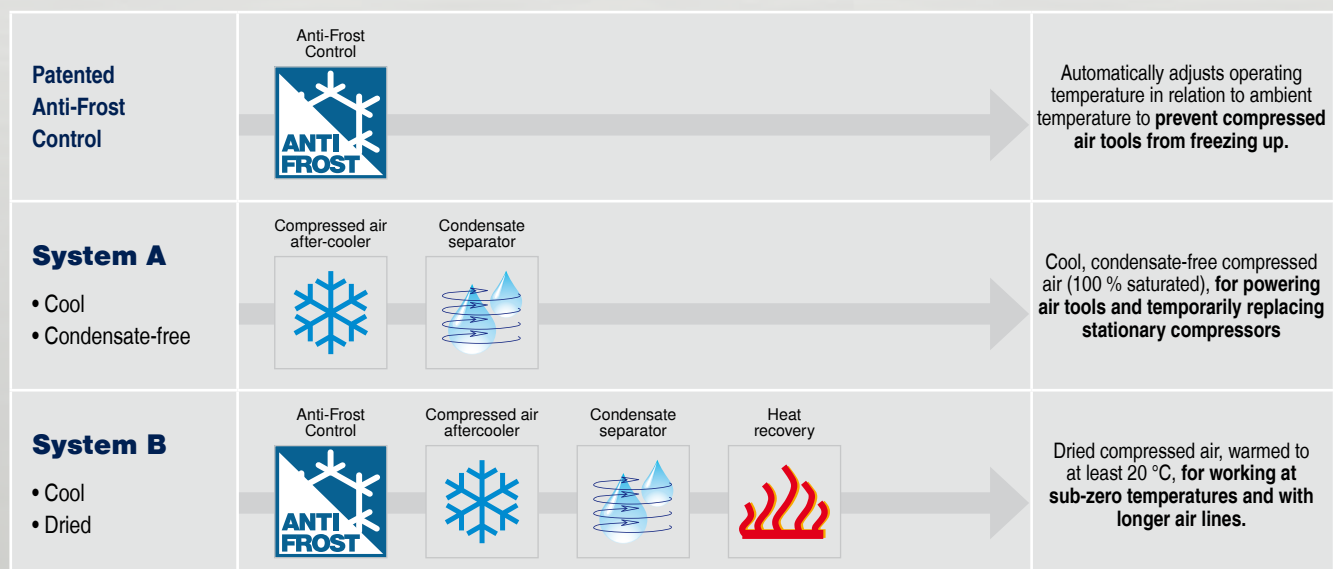

Other colours for the enclosure and custom paintwork for metal components are available upon request.

## Air treatment systems

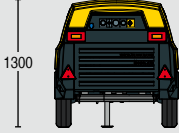
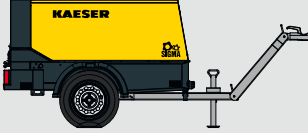

Additional air treatment systems for the MOBILAIR M 27 / M 31 are available upon request. Please contact Kaeser for further details.

## Dimensions

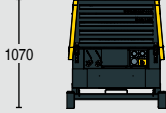
Portable with PE enclosure		Portable with metal enclosure	
			
2920 - 3450	1300 1260	2990 - 3520	1240 1260
Stationary version		Skids	
			
1790	1010 945	2025	1070 970

## Chassis

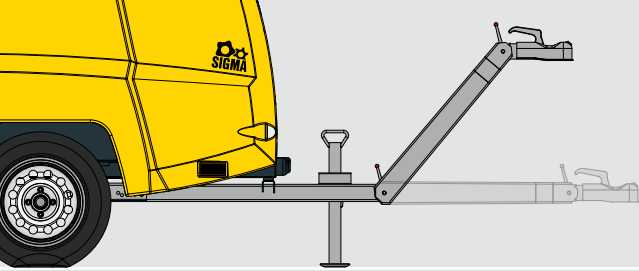
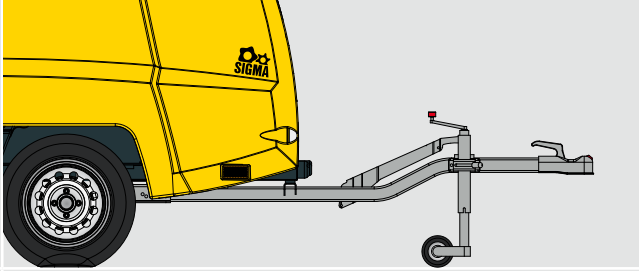
	
Height-adjustable towing hitch with / without run-on and parking brake	Fixed towing hitch with / without run-on and parking brake

## Technical Specifications

Model	Compressor		3-cylinder diesel engine (Water-cooled)					Complete unit					
	Flow rate	Working pressure	Make	Model	Rated motor power	Speed at full load	Idling speed	Fuel tank capacity	Operational weight	Sound power level	Sound pressure level	Compressed air connection	Compressed air treatment
	m <sup>3</sup> /min	bar			kW	rpm	rpm	l	kg**	dB(A)***	dB(A)****		
M 27	2.6	7	Kubota	D1105	17.9	2850	2100	40	555	≤ 98	67	2 x G 3/4	Option
M 31	3.15	7	Kubota	D1105T	24.1	2900	2100	40	560	≤ 98	69	2 x G 3/4	Option
	2.6	10											
	2.3	12											
	1.9	14											
M 31-G (6.5 kVA)	2.0	7	Kubota	D1105T	24.1	2900	2100	40	630	≤ 98	69	2 x G 3/4	Option
	3.0												

\*) At full power consumption

\*\*) Specified weight applies to standard PE enclosure unit without air treatment and equipped with an unbraked chassis and height adjustable tow bar

\*\*\*) Guaranteed sound power level as per directive 2000/14/EC

\*\*\*\*) Surface sound pressure level as per ISO 3744 (r = 10m)



# KAESER – The world is our home

As one of the world's largest manufacturers of rotary screw compressors, KAESER KOMPRESSOREN is represented throughout the world by a comprehensive network of branches, subsidiary companies and authorised partners in over 100 countries.

With innovative products and services, KAESER KOMPRESSOREN's experienced consultants and engineers help customers to enhance their competitive edge by working in close partnership to develop progressive system concepts that continuously push the boundaries of performance and compressed air efficiency. Moreover, the decades of knowledge and expertise from this industry-leading system provider are made available to each and every customer via the KAESER group's global computer network.

These advantages, coupled with KAESER's worldwide service organisation, ensure that all products operate at the peak of their performance at all times and provide maximum availability.

